

CANDY

CFT 910/4SXOVS

STANDARD HOOD

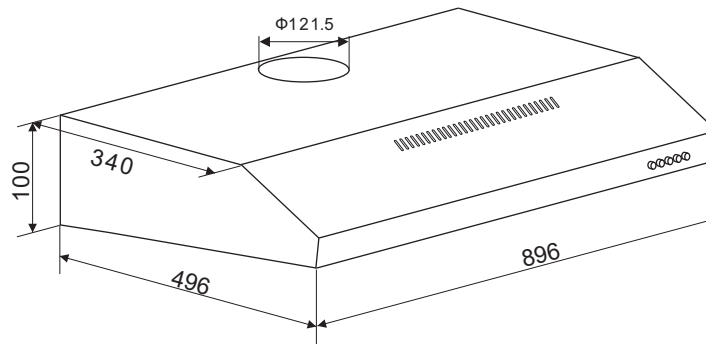

Itemname	CFT910/4SXOVS
Code	36901054
EAN code	8016361984998
Brand	CANDY
Dimensions (cm)	90
Finish/Color	Silver (Similar Inox)
Voltage	220-240 V
Frequency	50/60 Hz
Motor (number x power)	2*100w
Lighting (number x power - type)	1x28W halogen bulb
Total power	228W
Controls	Push button
Speed leVels	3 speeds
Energy data	
EEl / Energy Efficiency Index (Class / Value)	E-105.2
AEC / Annual Energy Consumption (kWh/a)	119.7
FDE / Fluid Dynamic Efficiency (Class / Value)	F-5.3
LE / Lighting Efficiency (Class / Value)	G-2.4
GFE / Grease Filter Efficiency (Class / Value)	E-59.5
RU - C(dB)	70
Min air flow in normal use QMIN (m3/h)	224.5
Max air flow in normal use QMAX (m3/h)	335.2
Measured air flow rate at best efficiency point QBEP (m3/h)	176.2
Measured air pressure at best efficiency point PBEP (PA)	179
A-weighted Sound Power Emission EN60704 at minimum speed DBMIN (dBa)	59
A-weighted Sound Power Emission EN60704 at maximum speed DBMAX (dBa)	70
A-weighted Sound Power Emission EN60704 at intensive or boost speed DBBOOST (ducted-recirculating) (dBa)	N/A
Measured electric power input at best efficiency point WBEP (W)	151.1
Power consumption off mode PO (W)	N/A
Power consumption stand by mode PS (W)	N/A
Nominal power of the lighting system WL (W)	28
Average illumination of the lighting system on the cooking surface EMIDDLE (lux)	66
Time increase factor F	2.4

Air flow EN61591 1st speed (ducted - recirculating) m3-h	145.4
Air flow EN61591 2nd speed (ducted - recirculating) m3-h	174.4
Air flow EN61591 3rd speed (ducted - recirculating) m3-h	285.6
Noise leVel sound power EN60704 1st speed (ducted - recirculating) dBa	69/70
Noise leVel sound power EN60704 2nd speed (ducted - recirculating) dBa	71/72
Noise leVel sound power EN60704 3rd speed (ducted - recirculating) dBa	73/74
ACCESSORIES	
Filters antigrease (number x type)	3 aluminium panels
Carbon filters (code / description / pcs x pack)	Carbon mat(CS100) x 3
Carbon filters (Included / Optional)	Included
Timer (included / minutes)	no
Air outlet (mm)	120
Wire lenght	1,5 m
Plug type	NO
OTHERS	
User Manual Languages	standard UM
Product dimensions	900*500*80
Packaging dimensions	930*120*540
Net weight	7.1
Gross weight	7.86
Loading 40"HC	1100